



Water



BESTOBELL
AQUATRONIX

SINCE / DEPUIS 1953

GWF

BEP-Bestobell
www.bestobell.com



Q-Eye Radar Portable

Mobile non-contact flow meter for open channels and partially filled pipes

Your benefits

- Non-contact measurement of flow and level:
No contact with fluid during installation, no sensor fouling or need for regular cleaning
- Easy mounting during continuous process:
Minimize installation costs and duration
- Platform-independent web interface for configuration, operation and maintenance:
Easy and fast setup with multi-language graphical user interface. Parametrization with any mobile device, no software needed
- Integrated Wi-Fi access point, mobile connection and FTP Push:
Real-time remote access of your data anytime and anywhere – no need to enter manhole
- Power supply with two redundant, hot-swappable Li-Ion batteries:
Reliable consistent measurement, no outages, 10 years battery lifetime

Application

- Open channels or partially filled pipes
- Ideal for harsh environments and heavily polluted water
- Temporary survey of flow in:
 - Wastewater treatment plants
 - Wastewater collection systems
 - Storm water runoff monitoring
 - Urban drainage

Features

- Portable lightweight HPX resin housing, IP67
- Two hot-swappable Li-Ion batteries
- Radar-based velocity sensor
- Ultrasonic, radar-based or hydrostatic level sensor
- Non-contact flow and level measurement
- Measurement of low velocities down to 0.05 m/s
- Bi-directional measurement over the entire flow range
- Uncertainty velocity: $\pm 0.5\%$ of reading ± 0.01 m/s
- Uncertainty flow: Typically $< 5\%$ of reading
- Integrated Wi-Fi access point
- Graphical user interface in multiple languages
- All units for display and data storage can be customized by the user
- Preselection of typical cross sections or user-definable irregular shapes
- Communication: 4G (LTE) modem with HSPA+ and 2G
- Includes internal storage capacity (16 GB)

Options

- Choice of ultrasonic, radar-based or hydrostatic level sensors
- Additional pressure transducer for surcharge conditions

Product description

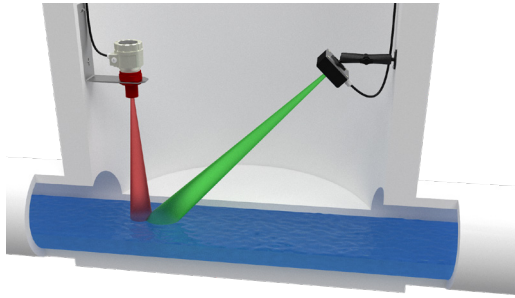

Q-Eye Radar with radar and level sensor

WebUI (Wi-Fi)

The Q-Eye Radar Portable is equipped with an integrated web server running a WebUI. You can display and manage the WebUI using the standard web browser of your smartphone, tablet PC or notebook. There is no need for any additional software or App. Parameter setting and data visualization has never been so easy.



Data storage and transmission

A 4G/3G/2G cellular modem for automatic data transmission is included. The logged data can be sent to any host computer (FTP server) or to the GWF web-based cloud solution at a user-selectable interval (e.g. 4 times a day, once a day or once a week). Alternatively, wireless LAN connection is available.

Information on level, velocity, flow and signal strength can be taken at regular intervals between 1 minute and 60 minutes. In case of a flood event, the logging can be set automatically to one minute (event mode). The Q-Eye Radar Portable is equipped with internal storage capacity (16 GB) and will store data for up to 18 months.

The Q-Eye Radar Portable flow meter is designed for mobile flow monitoring of slightly to heavily polluted media in open channels or partially filled pipes.

Q-Eye Radar Portable is an exceptionally versatile flow measurement system designed for temporary flow surveys and suitable for application not only in open channels, but also in municipal wastewater and storm water sewers. The non-contact measurement principle enables an easy installation and use. Additionally, the Q-Eye Radar Portable measures bi-directional flow over the entire measurement range and near zero flow velocities down to 0.05 m/s.

Measuring principle

For strongly polluted media or challenging installation sites, a non-contact measurement is often the method of choice. As the Q-Eye Radar Portable system can be mounted outside of the medium, your personnel will not get in contact with the polluted fluid during installation. Furthermore, the need for maintenance caused by sensor fouling or deposits is eliminated.

By combining both a radar velocity and a water level sensor, the Q-Eye Radar Portable provides a revolutionary approach to open channel and wastewater flow monitoring.

The velocity sensor sends a radar signal at an angle of approximately 55° to the surface of the water. The signal is then reflected back to the sensor. The local flow velocity can be measured based on the Doppler shift of frequency between the initially emitted and the reflected signal.

The level sensor is used to measure the height of the water at the exact point where the surface velocity was determined. Q-Eye Radar Portable calculates the area and total discharge based on the user-definable channel profile.

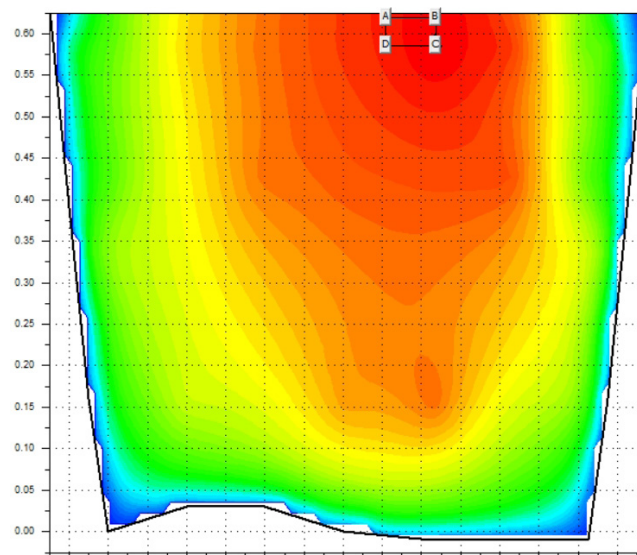

Component description

The Q-Eye Radar Portable system is composed of a mobile transmitter in an HPX resin case housing, a radar velocity sensor and any level sensor (ultrasonic, radar or pressure). For surcharge conditions, submersible level sensors are available.

Transmitter



Mobile transmitter case

The Q-Eye Radar Portable transmitter comes in an IP67 case ready for use in harsh environments, e.g. in sewer networks. The instrument can be read out without opening the case by simply activating Wi-Fi transmission. There is no need to connect any cable for data download or configuration.

All components of the flow meter are powered by 2 redundant Li-Ion batteries. The batteries are hot swappable, meaning they can be changed during operation. A 4G (LTE) modem with HSPA+ and 2G fallback is integrated in the transmitter.

Velocity and level sensors

RV11 radar velocity sensor



The radar velocity sensor is operating at the free 24 GHz band frequency and makes use of the Doppler effect to gain information about the speed of the moving surface. The sensor does this by beaming a microwave signal to the flow surface at a defined angle and analyzing the signal reflection from particles and disturbances moving with the flow. The frequency of this returning signal has been shifted by an amount directly proportional to the spot velocity.

Radar or ultrasonic level sensor



The ultrasonic level sensor operates by energizing a piezoelectric transducer with an electronic pulse. This pulse creates a pressure wave that travels to the flow surface and is partially reflected back to the transducer. The signal time of flight to the flow surface and back is recorded. The actual distance is calculated knowing the speed of sound at the site, which is corrected by an embedded temperature sensor.

Alternatively, the system can be equipped with an additional radar water level sensor, which is independent of ambient air temperature.

Surcharge level sensors



Pressure level sensor

For some applications, flow conditions change from open channel flow to surcharged conditions (e.g. in sewers). Down-looking level sensors cannot provide information when submerged. Consequently, Q-Eye Radar Portable can be equipped with an optional depth sensor (pressure transducer) which provides continuous measurement in surcharge events.

Technical data

Transmitter

Q-Eye Radar Portable

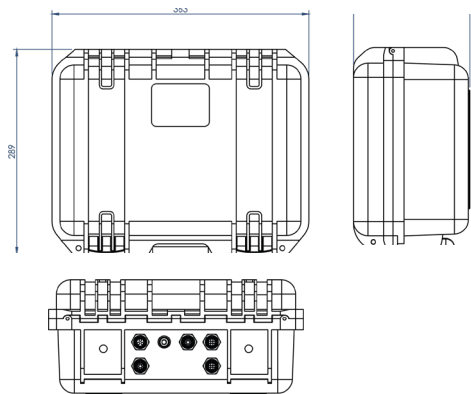

Display	4 lines, 20 characters
Keyboard	4 keys
Datalogger	16 GB Micro SD card
Communication	Wireless LAN, 4G (LTE) / 3G (HSPA+) / 2G
Inputs	max. 2 x 4-20 mA
Power supply	2 x rechargeable batteries, hot swappable, 24 V DC +/- 10% (option)
Protection class	IP67
Case material	HPX resin
Dimensions	289 x 363 x 163 mm (L x W x H)

Sensor

Radar velocity sensor

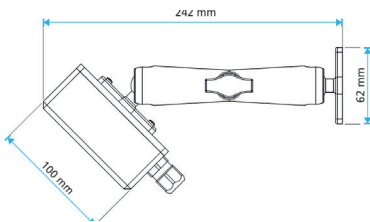

Frequency	24 GHz
Beam width	11° (-3 dB)
Range	± 0.05 m/s to ± 15 m/s
Resolution	1 mm/s min. wave height 3 mm
Uncertainty velocity	± 0.5 % of reading ± 0.01 m/s
Uncertainty flow	typically < 5 % of reading, depending on site conditions
Min. distance to surface	0.2 m
Max. distance to surface	10 m
Protection class	IP68 (48 h at 50 kPa, NEMA 6P)
Operating temperature	- 104 °F to + 185 °F
Dimensions	242 mm (L mounting), 100 x 100 mm (W x H sensor)

Q-Eye Radar Portable is available with a variety of ultrasonic and radar down-looking level sensors as well as a submersible pressure level sensor. Please consult the separate brochure for further details on the depth sensors.

BESTOBELL
AQUATRONIX
SINCE/DEPUIS 1953

Head Office
2880 Argentia Road, Unit 3
Mississauga, ON L5N 7X8
salesdesk@bestobell.com
1-800-668-3979
www.bestobell.com

Since 1953, Quality Products to Sense, Measure & Control
Depuis 1953, Produits De Qualités Pour Détecter, Mesurer & Contrôler

Montréal Office
970 Montée de Liesse, #204
St.Laurent, QC H4T 1W7
ventes@bestobell.com
1-877-331-1225

Atlantic Office
166 North Side Road
Riverport, NS B0J 2W0
dmossman@bestobell.com
902-529-0355

Headquarter
GWF MessSysteme AG
Obergrundstrasse 119
6005 Lucerne, Switzerland

T +41 41 319 50 50
info@gwf.ch, www.gwf.ch

Sales
GWF Technologies GmbH
Gewerbstraße 46f
87600 Kaufbeuren, Germany

T +49 8341-959990
info@gwf-technologies.de
www.gwf-technologies.de

printed in
switzerland

Subject to modification, 28.06.2021 – EPe60102