



Reflex VG7 26Ghz Radar level transmitter

Key Benefits

- Non-contact level measurement up to 40 metres (80 metres in special cases)
- Integral display of Level, Distance or Volume.
- High accuracy +/- 3mm
- Small blanking zone
- 2 wire loop powered 24vdc 4-20mA output.
- Optional all stainless steel construction
- Hazardous area ATEX Eex ia certification.
- HART, Profibus (PA) and Foundation Field bus.
- Suitable for narrow tanks with minimum fixed beam diameter.
- Unaffected by pressure, temperature, humidity, viscosity, foam or dust .
- Simple to install.
- Suitable for Aggressive liquids, hydrocarbons, toxic liquids and slurries. Granulated material and most solids.
- High temperature and pressure options are available.
- Remote or local programming, all tank parameters are held in local memory.
- Suitable for detecting levels through surface foam.
- Sealed Flange system allows electronics head removal under process conditions.
- TBF (Tank bottom following) mode available for low dielectric products
- ETS (Empty Tank Spectrum)mode damps out unwanted reflections

Frequency Modulated Continuous Wave — Operating Principle

The VG7 High frequency (26 GHz) Radar operates on the same proven principle of the earlier lower frequency 10 GHz FMCW Radars. A radar signal is emitted via an antenna, reflected by the target level and received after delay time 't' The high frequency signal (~26GHz) increases linearly by 2GHz during the measurement (frequency sweep) (1). The signal is emitted, reflected from the target surface and then received at a time-delayed frequency (2).

The difference Df , is calculated from the actual transmitted frequency and the received frequency (3). This difference is directly proportional to the distance measured The frequency difference is processed via a Fast Fourier Transformation (FFT) into a lower frequency spectrum and the actual distance / tank level is calculated from this spectrum.

Advantages of FMCW principle compared to Pulse Radar

- Better reflection separation
- Reliable noise reduction
- Smaller beam angle
- Fewer disturbing reflections
- Smaller antenna diameter for same measuring range



Enhanced accuracy Vs Pulse Radar

The difference in dynamic range between the best pulsed systems and the VG7 is more than 30 dB. This is equivalent in signal power to a sensitivity that is 1000 times greater. The larger dynamic range of the VG7 allows more stable detection of liquids with very low dielectric and thus very weak reflections. Between an dielectric of 2 and a dielectric of 1.2, in an otherwise identical measurement environment, the difference in level is approximately 11.5 dB, which is equivalent to 14 times the power difference on a linear scale. Given a large reserve in the dynamic range, (VG7) measuring accuracy will remain high even when signals are very weak, whereas in systems with a small dynamic range (pulse radar) measuring accuracy will decline rapidly when signals are weak.





Technically Advanced

Compared to the earlier 10 GHz units the main technical advantages are:

Stable, crystal-controlled high transmit frequency of 26 GHz and a larger bandwidth of 2 GHz

Dynamic range more than 100 dB.

Digital signal processing provides very high computing capacity. Complex evaluation algorithms ensure reliable and precise calculation of measured values.

The high average transmit frequency of 26 GHz provides better concentration and focus of the microwave signals, for improved accuracy, stability, and sensitivity, of the measured value.

The large 2 GHz bandwidth makes it easier to distinguish between wanted and unwanted signals, and measured values are evaluated with greater accuracy.

A dynamic range of more than 100 dB is attained using the FMCW principle. This determines the ratio between the strongest valid signals and the weakest possible signals in the form of fundamental noise

The unique Tank Bottom Following (TBF) mode enables products with low dielectric constants to be measured. For tanks with complex internal structures the Empty Tank Spectrum (ETS) can damp out all unwanted reflections from in tank obstructions. weakest possible signals in the form of fundamental noise.

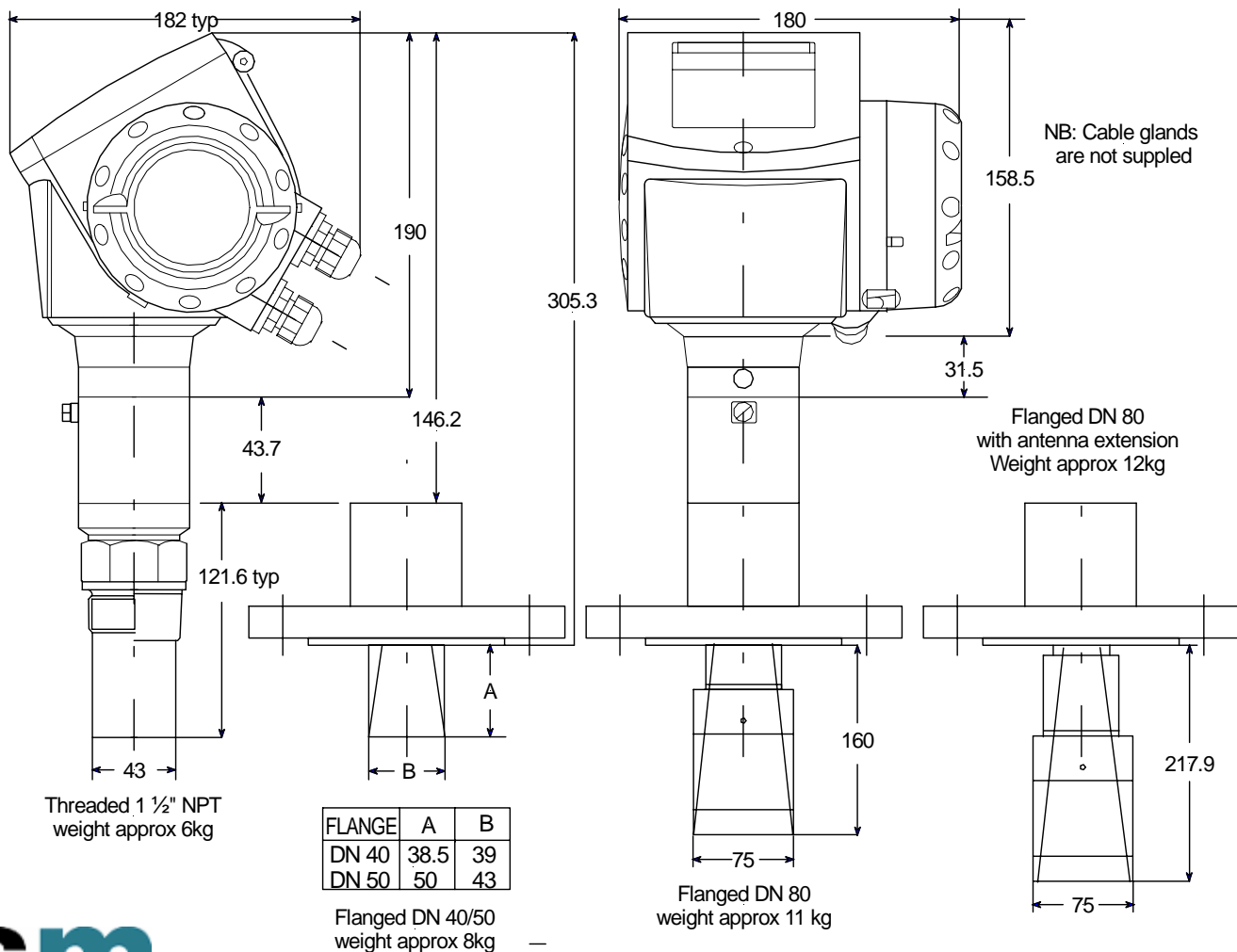

advice & enquiries

Telephone: +44 (0) 1444 410040

Fax: +44 (0) 1444 410121

Email: sales@psm-sensors.co.uk

Web: http://www.psm-sensors.co.uk

All rights reserved 2007

PSM Instrumentation Limited

Burrell Road Haywards Heath W Sussex RH16 1TW UK

T +44 (0) 1444 410040 F +44 (0) 1444 410121 W www.psm-sensors.co.uk E sales@psm-sensors.co.uk



Specifications

Input

Function:	K-band FMCW radar
Parameter:	Level, distance, volume and reflectivity
Minimum tank height:	0.5 m / 1.5 ft
Maximum measuring range:	40 m / 131 ft
Blocking Distance (dead zone):	Antenna extension length + antenna length + 0.1 m / 4"

Output

Output signal:	2 wire configuration. 4...20 mA HART® or 3.8 ... 20.5 mA acc. to NAMUR NE 43
Accuracy:	0.05% (rel. 20 mA; 20°C / 68°F)
Resolution:	±2 µA
Temperature drift:	Typically 50 ppm/K
Error signal:	High: 22 mA; Low : 3.6 mA according to NAMUR NE 43
Maximum Load:	350 ohm

Measuring accuracy

Reference conditions:	Temp. +20°C ±5°C
acc. to IEC770	Pressure 1013 mbar abs. ±20 mbar
	Relative air humidity: 60% ±15%
Resolution:	1 mm / 0.04 .
Accuracy:	±3 mm / ±0.12"
Beam angle:	DN 40 / ANSI 1 1/2"= 20°. DN 50 / ANSI 2"= 15°. DN 80 / ANSI 3"= 10°

Application conditions

Ambient temperature:	-40.+80°C / -40.+175°F; Eex i: -40.+60°C / -40.+140°F
Storage temperature:	-40.+85°C / -40.+185°F
Flange temperature:	-40.+200°C / -40.+300°F (Ex : refer to relevant device's approval and temperature class)
Thermal shock resistance:	100°C/min
Operating pressure:	-1.40 bar / -14.5.580 psig; subject to process connection used and flange temperature
Dielectric constant :	2.0 or greater (1.5 or greater if stilling well used)
Vibration resistance:	IEC 68-2-6 and prEN 50178 (10...57Hz: 0.075 mm / 57...150 Hz: 1 g)
Protection category:	IP 66/67 equivalent to NEMA 6-6X

Mechanical data

Material Housing:	Epoxy coated Aluminium, Optional Stainless steel
Wetted parts:	Stainless steel (1.4404 / 316L); Hastelloy C-22 (2.4602)
Process fitting:	Stainless steel (1.4404 / 316L); Hastelloy C-22 (2.4602)
Gaskets:	Viton (-40.+150°C / -40.+300°F); Kalrez 6375 (-20.+150°C / -5 .+300°F)
Process connection:	Thread G 1 1/2"; NPT 1 1/2" Flange: DN 40.DN 150 (PN 40 / PN 16); 1 1/2".8" (150 lb / 300 lb); 10 K (40.100A)

Electrical connection

2-wire power supply:	Connected to output Terminals (2 wire configuration) Non-Ex / Eex i 24 V DC (14 . 30 V DC) Eex d 24 V DC (20 . 36 V DC)
Cable entry:	M20x 1.5; NPT 1/2"; G 1/2"
Terminals:	0.5. To 1.5 mm²

Human machine interface

Display:	9 lines, 160 x 160 pixels in 8-step grey scale with 4-button key pad
Operating languages:	English (UK), German, French, Italian, Spanish, Portuguese, Japanese, Mandarin, Russian.

Approvals

Overfill protection:	WHG
ATEX:	ATEX II G/D 1, 1/2, 2 EEx ia IIC T6; ATEX II G/D 1/2, 2 EEx d ia IIC T6
FM:	IS class I Div . 1 Gr. A...G; XP class I Div . 1 Gr. A.G
CSA	IS class I Div . 1 Gr. A...G; XP class I Div . 1 Gr. A.G

Flexibility by Modular design

PSM

advice & enquiries

Telephone: +44 (0) 1444 410040

Fax: +44 (0) 1444 410121

Email: sales@psm-sensors.co.uk

Web: http://www.psm-sensors.co.uk

All rights reserved 2007

PSM Instrumentation Limited

Burrell Road Haywards Heath W Sussex RH16 1TW UK

T +44 (0) 1444 410040 F +44 (0) 1444 410121 W www.psm-sensors.co.uk E sales@psm-sensors.co.uk