



SOBA SMALL



FLOAT LEVEL REGULATOR

For automatic regulation with several devices



USE

VR – Emptying / Filling

SIZE

Height: 130 mm – Diameter: 70 mm

DIFFERENTIAL ANGLE

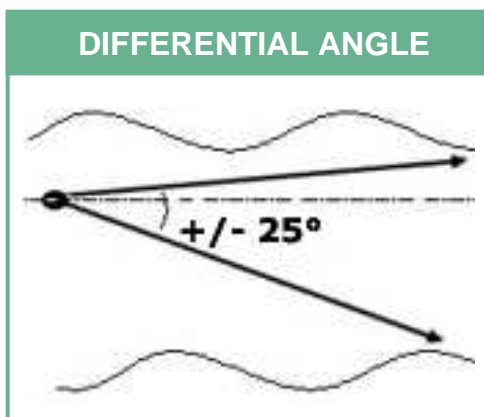

WIRING

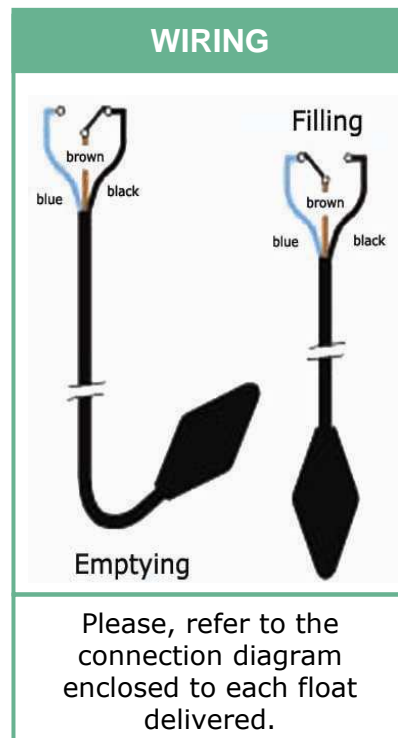

APPLIANCES

Suitable for various liquids. Similar to the SOBA but with a smaller size. Especially adapted to small tanks and domestic or collective prefabricated pumping stations. Can be used as an «ALARM» detector. (please, refer to the SOBA technical sheet)

TECHNICAL CHARACTERISTICS

Operation mode	Omnidirectional
Allowed fluid density	0,70 a 1,25
Maximum pressure	3,5 bars
Maximum temperature	85°C
Protection index	IP 68 <input type="checkbox"/>
Electric characteristics	12, 24, 48 VAC/VDC et 250 VAC- 50/60 Hz
Cut-out power	16 (6) A (16 A résistive - 6 A inductive)
Microswitch	Silver / nickel reverser contacts
Biconical shell	Copolymer polypropylene
Cable	Neoprene or HR HY (hypalon) H07RN8-F
Cable type	3 conductors 1 mm ²
Float weight without cable	110 g
Cable weight	Neoprene 115 g/m – HR HY 110 g/m
Adjustable ballast on cable (series)	Loaded resin 250 g
Standard cable length (series)	5, 6, 10, 13, 15, 20 and 25 m (other lengths on request)