



Combustible Gas Sensor

Toll Free: 888-367-4286
Phone: 281-367-4100
Fax: 281-292-2860

Internet: <http://www.detcon.com>
e-mail: sales@detcon.com

Matched Pair Catalytic Bead

Model FP-524C

(order by part number 965-525410-100)



SPECIFICATIONS

Sensor Type

Matched-pair catalytic bead

Measurement Range

0-100% LEL (lower explosive limit)
Combustible Gas

Accuracy/Repeatability

±3% 0-50% LEL
±5% 50-100% LEL

Response/Clearing Time

T50 <10 seconds
T90 <30 seconds

Zero Drift

<5% per year

Operating Temperature Range

-40°F to +167°F; -40°C to +75°C

Operating Humidity Range

0-99% RH non-condensing

Output

Linear 4-20 mA DC

Input Voltage

11.5-28 VDC

Power Consumption

1.9 watts @ 24 VDC

Electrical Classification

Explosion proof
Class I, Division 1, Groups B, C, D

Safety Approvals

CSA/NRTL (US OSHA Certified)

Sensor Life/Warranty

Sensor: 2 year warranty
Transmitter: 2 year warranty

Shipping Weight

6 lbs.

Packing Dimensions

12" x 12" x 9"

MicroSafe™ Intelligent Sensor

DESCRIPTION

Detcon Model FP-524C sensors are non-intrusive "Smart" sensors designed to detect and monitor Combustible Gas in air over the range of 0-100% LEL (lower explosive limit). The sensor assembly consists of a matched-pair catalytic bead sensor in a stainless steel housing, a plug-in control transmitter circuit, a base connector board and an explosion proof enclosure.

- CSA-NRTL Approved: Class I, Division 1, Groups B, C, & D
- Simple menu driven calibration - takes less than 3 minutes to perform
- Backlit LCD and LED indicators for FAULT and CAL status
- Plug-in field-replaceable transmitter and sensor
- Long sensor life expectancy: averaging longer than five years in harsh offshore drilling/production environment
- High resistance to poisons such as sulfides, chlorides, silicon-based contaminants etc.
- Low power consumption (less than 2 watts versus 7+ watts on competitive brands)

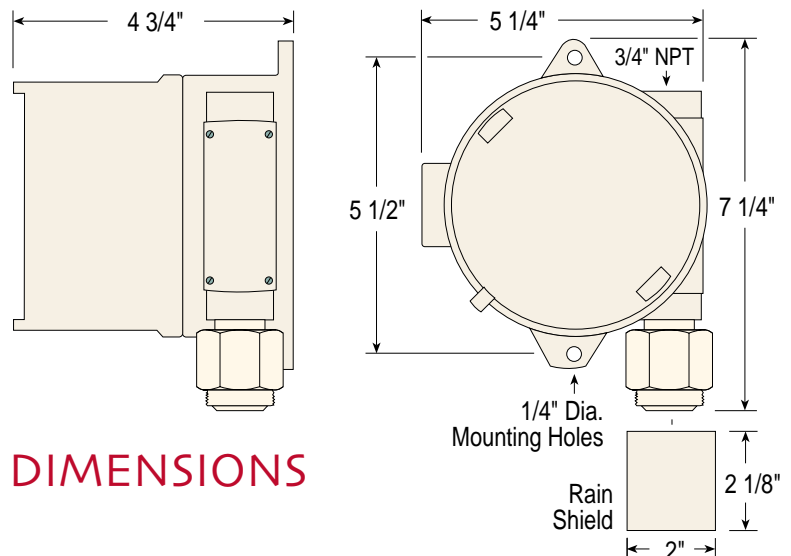

DIMENSIONS