

Meters



See-Flo® Meters indicate flow rate and permit visual inspection of water, air or other transparent fluids. For general purpose industrial service, See-Flo® meters handle a wide range of process fluids in vertical or horizontal piping runs.

The wedge shape of the meter housing makes See-Flo® practically self-cleaning. Where periodic maintenance might be necessary, the tempered glass window is easily removed and replaced.

Features

- Instantaneous flow rate measurement.
- Observe fluid conditions for color, clarity and flow.
- Use in horizontal or vertical piping systems.
- Individually calibrated for fluid and operating conditions.
- User selectable 10:1 turndown flow ranges. (See Meter Rangeability Sizing Tables)
- User selectable units of measure including dual units of measure.
- No floats to get stuck, tubes to break or dynamic seals to leak.
- Low pressure loss.
- Simple design with few parts for long service life.

Principle of Operation

See-Flo® meters are variable area flow rate meters. The internal volume of the housing enlarges from the inlet to the outlet. The primary element is a tempered alloy vane with one end affixed to the apex of the meter housing. As the flow rate changes, the vane is flexed indirect proportion.



The ½", ¾", and 1" connections typically have female threaded ends. Sizes 1¼" through 6" utilize a shunt design.

This integral by-pass housing enables larger connection sizes in the format of a spool with a constant 12" end to end dimension. In addition, it permits a wide variety of connection types which include threaded, flanged, grooved ends and tri-clamp.

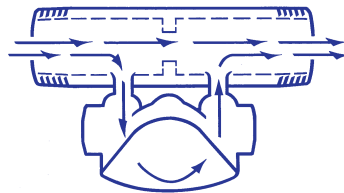

Applications

- Water
- Air
- Nitrogen
- Vacuum service
- Other transparent liquids or gases.

Specifications

Accuracy:	± 2% full scale
Repeatability:	±1% full scale
Scales:	Direct reading
Resolution:	Maximum - 30 divisions Minimum - 15 divisions
Materials of Construction:	(wetted parts)
Housing:	aluminum, brass or 316 stainless steel
Shunt:	housing material or carbon steel
Window:	tempered glass
Vane:	17-7 ph stainless steel
"O" Rings:	Buna-n, ethylene propylene, Viton® or Kalrez®

Meters

1/2", 3/4", & 1" connections

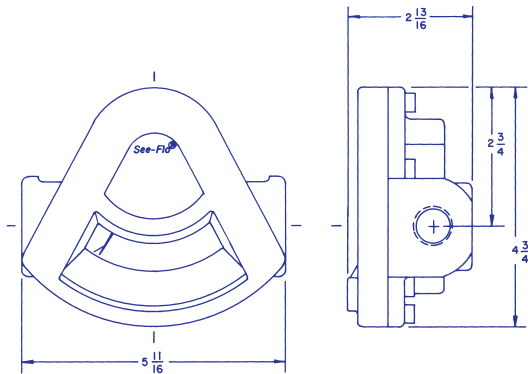

1 1/4" to 6" connections

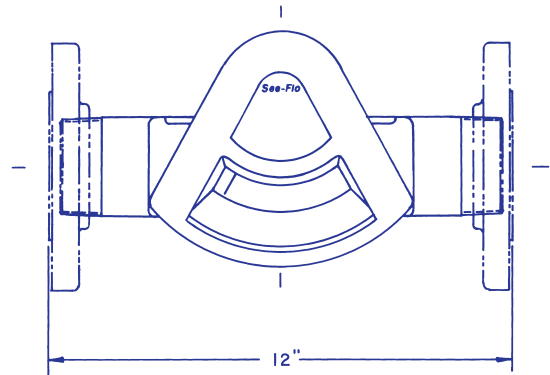

Piping Connections:

- 1/2" to 1" NPT Female
- 1 1/4" to 4" NPT Male
- 1/2" to 3" Tri-clamp
- 1 1/4" to 6" Grooved
- 1 1/4" to 6" Beveled
- 1/2" to 6" 150#/300# RF/FF ANSI Flanges (carbon stl)
- 1/2" to 6" 150# RF ANSI Flanges (stainless steel)
- 1/2" to 6" 150#/300# RF ANSI Flanges (aluminum)
- 1/2" to 6" 150# FF ANSI Flanges (brass)
- 15 to 25 mm DIN 2999/BS21/ISO R7 Female threaded
- 15 to 150 mm DIN PN 10 Flanges (316 stainless stl & carbon stl)

Pressure Limits: 200 psig (13.8 bar)

Temperature Limits:

- 23 to 85°C (-10 to 185°F) with Teflon® o-ring at constant temperature conditions.
- 23 to 85°C (-10 to 185°F) with polycarbonate window.
- 23 to 121°C (-10 to 250°F) with buna-n o-ring.
- 23 to 204°C (-10 to 400°F) with Viton® or ethylene propylene o-ring.

Not intended for use with opaque liquids or steam. ERDCO reserves the right to alter design and/or specifications without notice. Viton® and Kalrez® are registered trademarks of E.I. duPont de Nemours and Co.

Model Number System

The example 3221-12F5 describes a 3200 Series See-Flo® meter with a brass body/carbon steel shunt for left to right flow. Connections are 3" 150# raised carbon steel flanges.

32 Series	2 Housing Material	1 Flow Direction	12 Size	F Type	5 Shunt Material
32-3200	1 -Aluminum 2 -Brass 6 -Stainless Stl	1 -L to R 2 -R to L 3 -Up 4 -Down	02 -1/2" (15mm)	T -NPT End	0 -None 1 -Aluminum 2 -Brass 5 -Carbon Steel 6 -Stainless Steel
			03 -3/4" (20mm)	R -NPT Back	
			04 -1" (25mm)	S -Tri-clamp	
			05 -1 1/4" (32mm)	G -Grooved	
			06 -1 1/2" (40mm)	X -Beveled	
			08 -2" (50mm)	W -Socket End 1/2"-1"	
			10 -2 1/2" (65mm)	F -Flange 150#RF	
			12 -3" (80mm)	H -Flange 150#FF	
			16 -4" (100mm)	J -Flange 300#RF	
			20 -5" (125mm)	K -Flange 300#FF	
			24 -6" (150mm)	L -Flange DIN PN 10	
				M -Metric Thread End	
	N -Metric Thread Back				