

## General Purpose Flowmeter



Measure liquid, gas or steam flow rates in horizontal or vertical pipelines. Armor-Flo™ meters handle fluids that cannot be measured with the See-Flo® due to clarity, pressure or compatibility with wetted materials.

The wedge shape of the meter body housing provides the Armor-Flo™ with the same self-cleaning characteristics as the See-Flo®. Teflon® encapsulated cobalt magnets are used to couple the flow isolated indicator with the vane. These features emphasize simplicity and reduce maintenance.

### Features

- Instantaneous rate measurement.
- Measure opaque fluids.
- More exotic materials of construction.
- Use in horizontal or vertical piping systems.
- Individually calibrated for fluid and operating conditions.
- User selectable 10:1 turndown flow ranges. (See "Meter Rangeability Sizing Tables")
- User selectable units of measure-including dual units of measure.
- No floats to get stuck, tubes to break or dynamic seals to leak.
- Low pressure loss.
- Simple design with few parts for long service life.

### Principle of Operation

Armor-Flo™ meters are variable area flow rate meters. The Armor-Flo™ body housing has a variable internal volume which enlarges from the inlet to the outlet.



The primary sensor is a tempered alloy vane with one end affixed to the apex of the meter housing. As the flow rate changes, the vane is flexed in direct proportion. A Teflon® encapsulated magnet links the vane with the pointer in a large indicator housing for easy viewing.

The ½", ¾" and 1" connections typically have female threaded ends. Sizes 1¼" through 6" utilize a shunt design. This integral by-pass housing enables larger connection sizes in the format of a spool with a constant 12" end to end dimension.

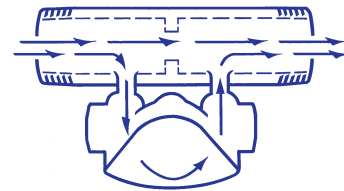

In addition, it permits a wide variety of connection types which include threaded, flanged, grooved ends and tri-clamp.

### Applications

- Water
- Liquids with viscosity up to 300 Cst.
- Air and other gases
- Vacuum service
- Steam

### Specifications

<b>Accuracy:</b>	±2% full scale
<b>Repeatability:</b>	±1% full scale
<b>Scales:</b>	Direct reading
<b>Resolution:</b>	Maximum-30 division/Minimum-15 divisions
<b>Rangeability:</b>	10 to 1 turndown
<b>Materials of Construction:</b>	
Housing:	Aluminum, brass, 70/30 copper/nickel, 316 stainless steel, Hastelloy® C-22
Shunt:	As housing or carbon steel
Window:	Tempered glass or polycarbonate
Vane:	Cobalt/chromium/nickel alloy or Hastelloy® C-22 with Teflon® encapsulated magnet
"O" rings:	Buna-n, ethylene propylene, Vitor®, Kalrez® or Teflon®
<b>Piping Connections:</b>	
	½" to 1" NPT Female
	1¼" to 4" NPT male
	1½" to 3" Tri-clamp
	1¼" to 6" Grooved
	1¼" to 6" Beveled
	½" to 6" 150# /300# RF/FF ANSI Flanges (carbon stl)
	½" to 6" 150# RF ANSI Flanges (stainless stl)
	½" to 6" 150# RF ANSI Flanges (aluminum)
	½" to 6" 150# FF ANSI Flanges (brass)

## General Purpose Flowmeter

### 3400 Series 1/2", 3/4", & 1" connections

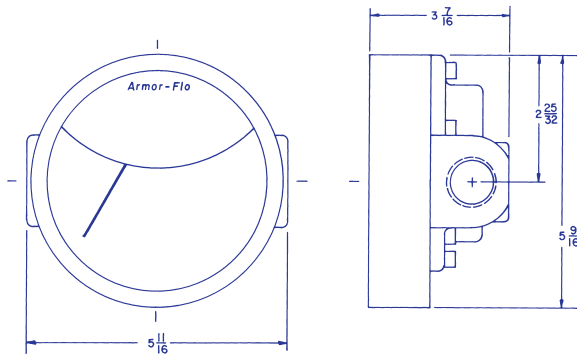

- 15 to 25 mm DIN 2999/BS21/ISO R7  
Female threaded
- 15 to 150 mm DIN PN 10 Flanges  
(316 stainless stl & carbon stl)

- Pressure Limits:**
- 1 Housing (aluminum)
    - 0, 1 or 5 Shunt-200 psig (13.8 bar)
  - 2 Housing (brass)
    - 0 Shunt-400 psig (27.6 bar)
    - 2 or 5 Shunt-200 psig (13.8 bar)
  - 6 Housing (316 stainless stl)
    - 0 Shunt-400 psig (27.6 bar)
    - 5 or 6 Shunt-200 psig (13.8 bar)
    - 7 or 8 Shunt-400 psig (27.6 bar)
  - 8 Housing (high pressure 316 stainless stl)
    - 0 Shunt-1000 psig (69 bar)
  - 9 Housing (Hastelloy® C-22)

### 3400 Series 1 1/4" to 6" connections

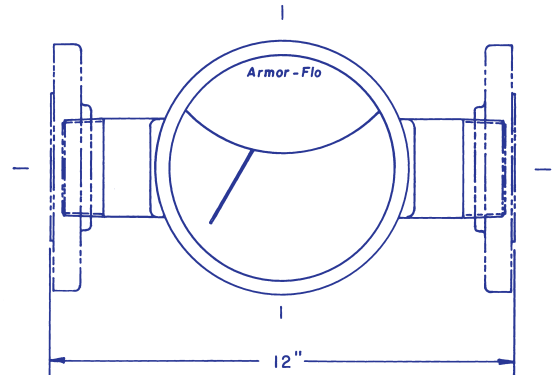

- 0 Shunt-400 psig (27.6 bar)

**Temperature Limits:**

- 23 to 85°C (-10 to 185°F)  
with Teflon® o-ring at constant  
temperature conditions
- 23 to 121°C (-10 to 250°F)  
with buna-n o-ring
- 23 to 204°C (-10 to 400°F)  
with Viton®, Kalrez® or ethylene  
propylene o-ring

ERDCO reserves the right to alter design and/or specifications without notice. Viton®, Teflon®, and Kalrez® are registered trademarks of E.I. duPont de Nemours and Co. Hastelloy® is a registered trademark of Haynes International, Inc.

### Model Number System

The example **3461-12F5** describes a 3400 Armor-Flo™ meter with a stainless steel body/carbon steel shunt for left to right flow. Connections are 3" 150# raised carbon steel flanges.

<u>34</u> Series	<u>6</u> Housing Material	<u>1</u> Flow Direction	-	<u>12</u> Size	<u>F</u> Type	<u>5</u> Shunt Material
34-3400	1-Aluminum 2-Brass 6-Stainless Stl 8-Stainless Stl 1000 psig 9-Hastelloy® C-22	1-L to R 2-R to L 3-Up 4-Down		02-1/2" (15mm) 03-3/4" (20mm) 04-1" (25mm) 05-1 1/4" (32mm) 06-1 1/2" (40mm) 08-2" (50mm) 10-2 1/2" (65mm) 12-3" (80mm) 16-4" (100mm) 20-5" (125mm) 24-6" (150mm)	T-NPT End F-Flange 150#RF G-Grooved H-Flange 150#FF J-Flange 300#RF K-Flange 300#FF L-Flange DIN PN 10/15 M-Metric Thread End N-Metric Thread Back P-Flange 600#RF R-NPT Back S-Tri-clamp W-Socket End 1/2"-1" X-Beveled	0-None 1-Aluminum 2-Brass 5-Carbon Steel 6-Stainless Steel 7-Carbon Steel 400 psig 8-Stainless Steel 400 psig